

JAMES J. DEAN
Superintendent of Highways
Roadmaster IV

Orangetown Representative:

R.C. Soil and Water Conservation Dist.-Chairman
Stormwater Consortium of Rockland County
Rockland County Water Quality Committee



**HIGHWAY DEPARTMENT
TOWN OF ORANGETOWN**

119 Route 303 • Orangeburg, NY 10962
(845) 359-6500 • Fax (845) 359-6062
E-Mail – highwaydept@orangetown.com

Affiliations:

American Public Works Association NY Metro Chapter
NYS Association of Town Superintendents of Highways
Hwy. Superintendents' Association of Rockland County

April 21, 2021

Dear Interested Party:

The Town of Orangetown Highway Department, in conjunction with the Department of Environmental Management and Engineering and the Rockland County Department of Public Transportation have prepared a public informational briefing for the Orangetown Commuter Parking Facility Project to be located at 650 Route 340 in Sparkill, NY.

The briefing will take place on May 5, 2021 at 6:00 PM and be held in the parking lot of the Palisades Sparkill Baseball League across from the American Legion, John M. Perry Post #1044, 620 Route 340, Sparkill, NY.

The purpose of the briefing is to obtain comments on the proposed project from individuals, groups, officials and local agencies.

The project design and plans are accessible via the following website, <https://www.orangetown.com/groups/department/highway/>.

Project design and plans can also be accessed and reviewed in-person at: the Orangetown Highway Department (119 Route 303, Orangeburg, NY 10962) between the hours of 8am and 3:30pm (Monday to Friday). Comments can be handwritten and submitted at the time or submitted afterward through Friday, May 14, 2021. Please note that persons reviewing the project plans at the Highway Department will be subject to County Covid-19 protocol, which includes wearing an approved face covering and receiving a non-invasive temperature check upon entering the premises.

I hope you will be able to attend this meeting. If you have any questions regarding this or any other highway related matter, please contact Stephen F. Munno, Sr. Administrative Assistant at (845) 359-6500 or you may reach him via e-mail at highwaydept@orangetown.com.

Very truly yours,

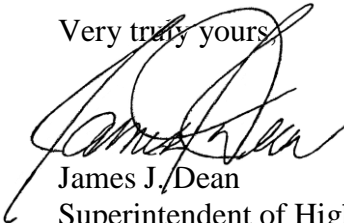

James J. Dean
Superintendent of Highways

JJD/sfm



Good Evening Supervisor Kenny, members of the Town Board and members of the public:

As the Supervisor's office has received a few questions regarding filming – the interruption of and the cost effectiveness in Orangetown, I thought it best to give a break down of revenue regarding the first quarter.

Through March 31st:

Permits issued: 55

Film Revenue: \$ 156,825.00

Police Revenue: \$ 132,431.25

(Police revenue fees are based on the hourly rate for a police officer, as well as their benefits.)

Compared to 2020, first quarter:

Permits issued: 17

Film Revenue: \$ 64,650.00

Police Revenue: \$ 89,337.50

Compared to 2019, first quarter:

26

\$ 77,550.00

\$ 54,381.25

(Police revenue fees are based on the hourly rate for a police officer, as well as their benefits.)

The majority of filming has come from television shows – FBI Most Wanted, The Blacklist, Manifest and The Prodigal Son. The town has been host to commercials as well – Butterfinger, Dicks Sporting Goods and some medical labs, to name just a few.

With tv shows starting to wrap up their seasons, we have noticed that more commercials and movies are now requesting film permits in our area. The good news with movies is that they tend to stay in one place for a longer period of time, as opposed to television shows, which are constantly moving about our town.

With heavy restrictions still in place in New York City and dealing personally with location scouts and producers, all appear to be very happy filming in Orangetown. Periodically I receive cold calls from producers who have read great reviews about the Town of Orangetown on various social media pages and they can't wait to do business in Orangetown. The film companies have shot in all seven hamlets (as well as the Pfizer and HNA complex's) and every time they come back, they find another hidden gem. I know how happy I am when I sit down to watch a show and I recognize our hamlets on a nationwide show.

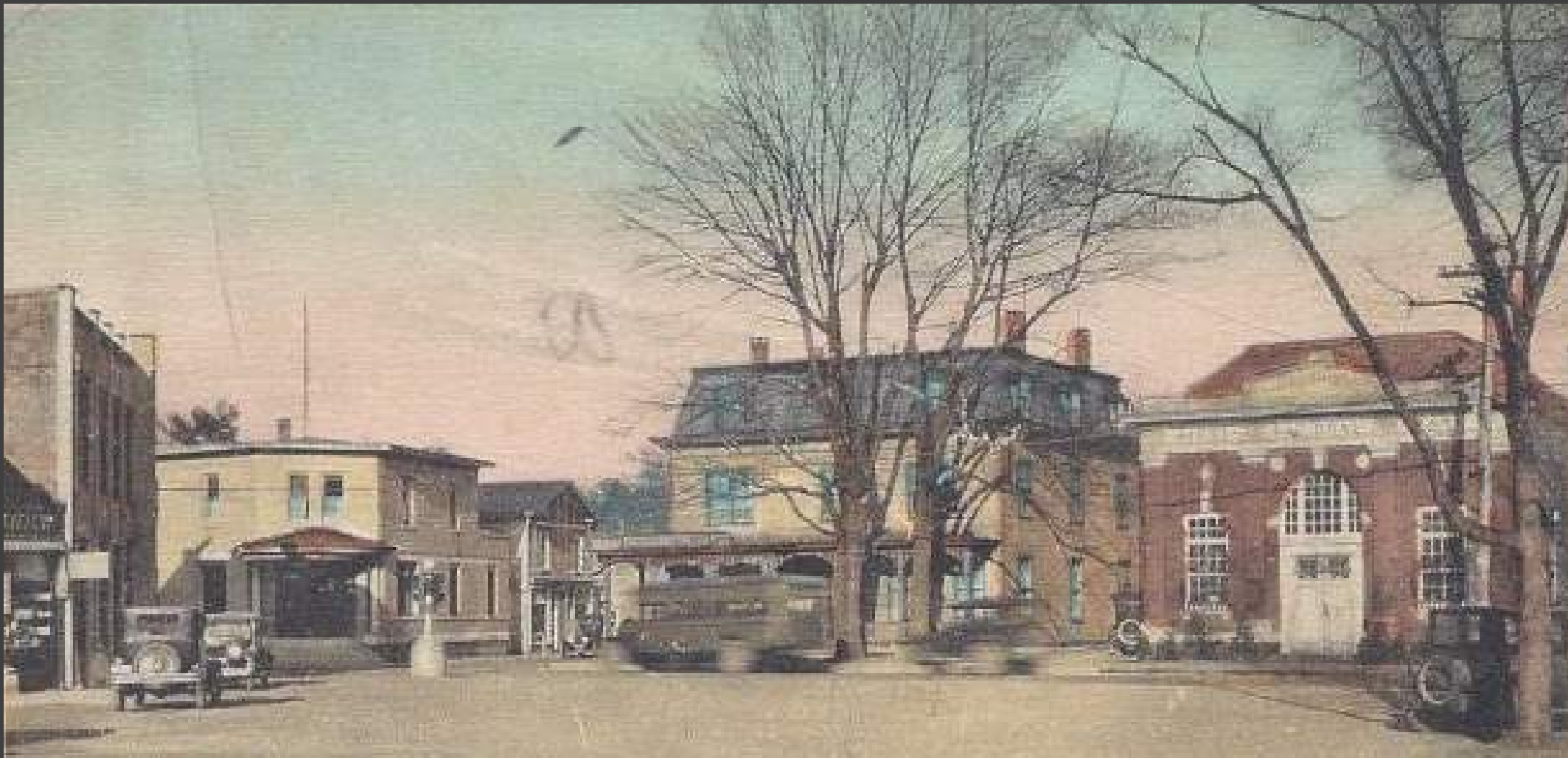

sparkill center, sparkill, NY circa 1920's

S P A R K I L L M E W S



INSPIRATION FOR SPARKILL MEWS

Sparkill Mews

is a mixed use, Net-Zero, residential and commercial development proposed for the former Chase Bank property in Sparkill Center. The site is in the Overlay District which encourages a more flexible interpretation of zoning regulations for new development in historic hamlets.

Apartments are sited along a private, pedestrian-scaled street that connects Main Street with Paulding Place. Along Main Street, the proposed new construction reflects the mix of two and three -story residential and commercial units that have defined the fabric of Sparkill for over a hundred years.

Important Features:

- Sparkill Mews will be a Net-Zero residential and commercial development – that is, it will produce more energy than it uses.
- New construction respects the scale and materials of Main Street, as well as utilizing architectural details of our own time such as generous, high-performance windows, solar panels and sustainable building materials.
- The site design incorporates the refurbished 106 year-old Chase bank building as part of the ensemble of the mews.
- Plantings, terraces, roof and vertical gardens will enliven both the interior and the public streetscape.
- Market rate apartments will add to the mix of available housing choices for the residents of Orangetown.

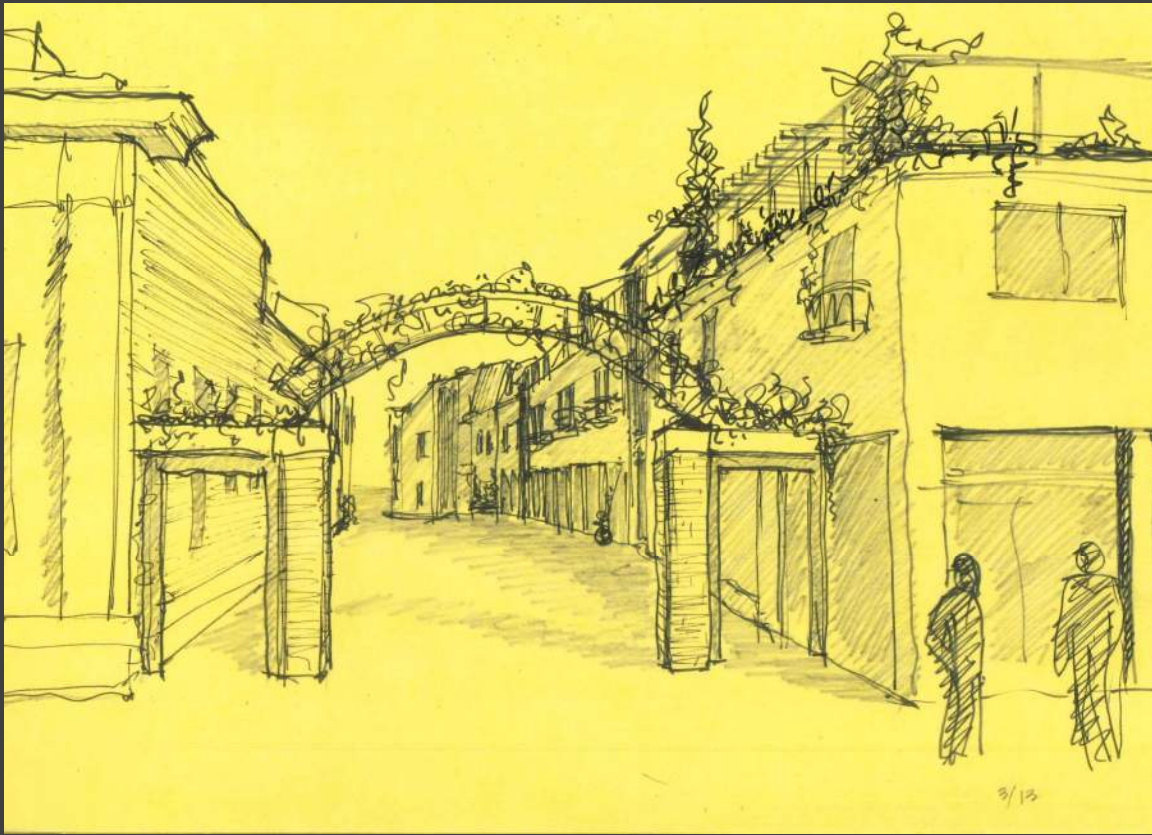

West Entry



East Entry

S P A R K I L L M E W S

AROUND THE CORNER:
UNION ARTS CENTER
ROOST RESTAURANT



COMMERCIAL /
RESIDENTIAL ABOVE

BANK BLDG. /
NEW COMMERCIAL

MEWS

NEW COMMERCIAL /
RESIDENTIAL

EXISTING
SINGLE-FAMILY
HOUSES

VIEW ALONG MAIN STREET

S P A R K I L L M E W S



SPARKILL POST OFFICE



OFFICE BUILDING



CAFÉ/STORE/RESIDENTIAL



BANK BLDG.



PARKING LOT
LOCATION OF PROPOSED DEVELOPMENT



RESIDENCES



DEPOT SQUARE

NEW RESIDENTIAL AND
COMMERCIAL BUILDING

MEMORIAL PARK

SPARKILL MEWS

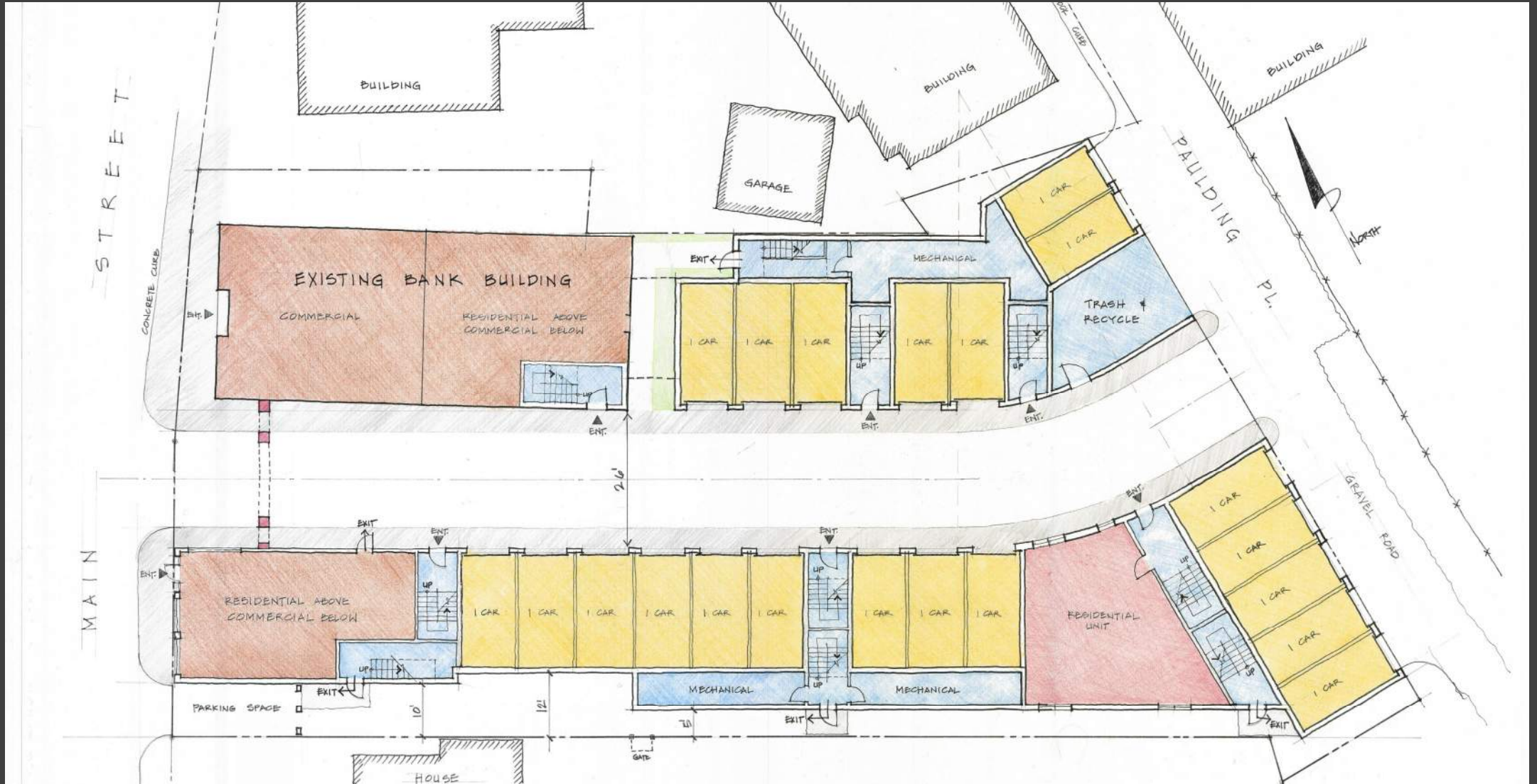

SPARKILL MEWS



RESIDENCES

RESIDENCE
ABOVE COMMERCIAL

VIEW FROM THE NORTH
ALONG THE MEWS

SPARKILL MEWS



RESIDENCE
ABOVE COMMERCIAL

RESIDENCES

VIEW FROM THE SOUTH

SPARKILL MEWS

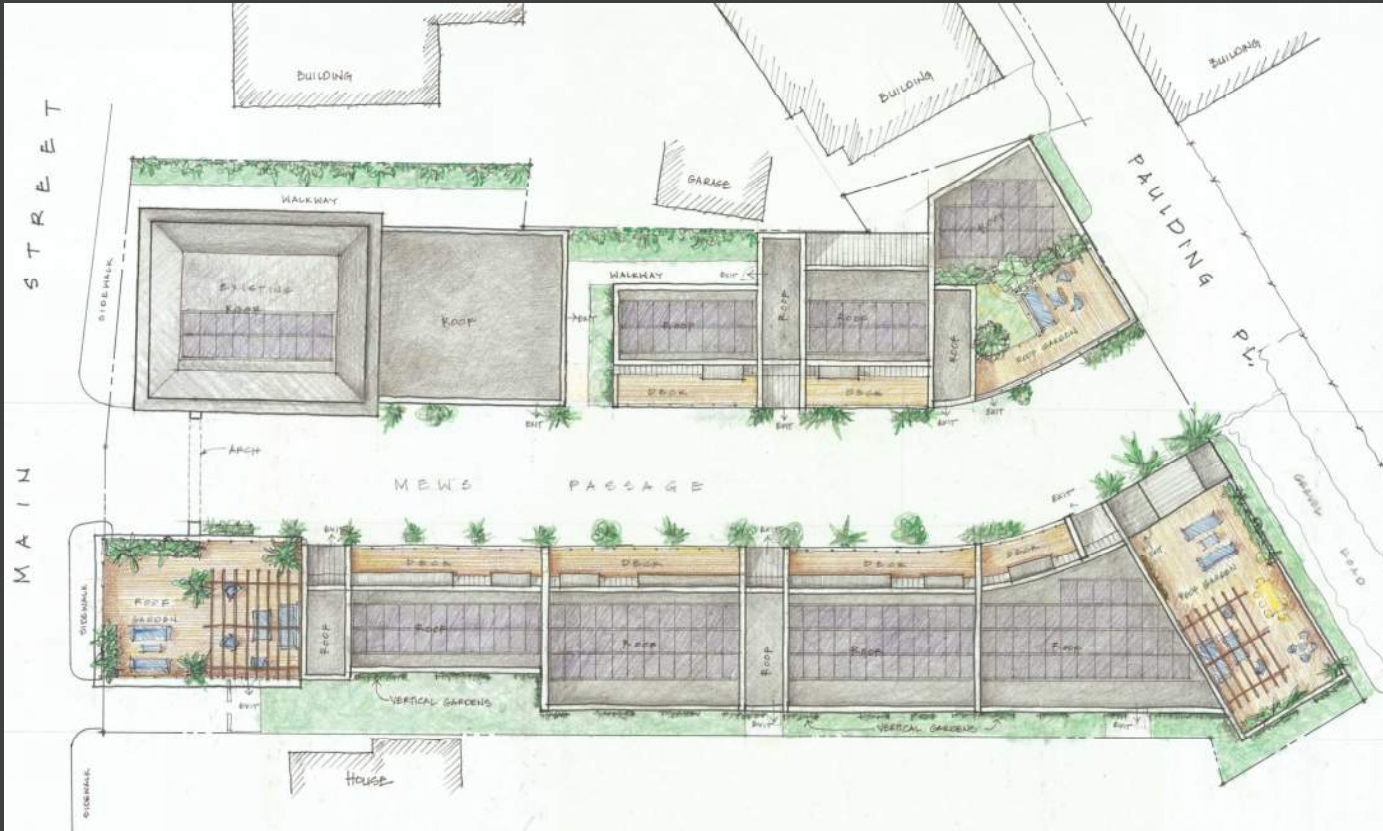

Roofscape and Landscape

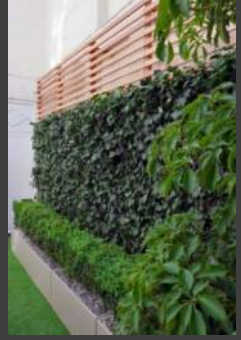

Vertical Gardens

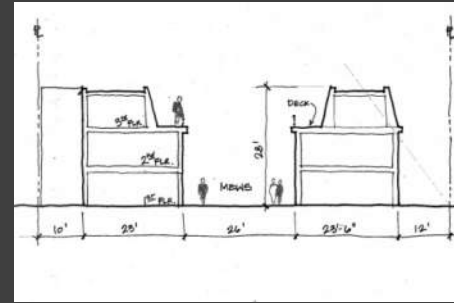

Cross-section thru Site



Rooftop Gardens

SPARKILL MEWS

JAMES J. DEAN
Superintendent of Highways
Roadmaster IV

Orangetown Representative:
R.C. Soil and Water Conservation Dist.-Chairman
Stormwater Consortium of Rockland County
Rockland County Water Quality Committee



HIGHWAY DEPARTMENT
TOWN OF ORANGETOWN
119 Route 303 • Orangeburg, NY 10962
(845) 359-6500 • Fax (845) 359-6062
E-Mail – highwaydept@orangetown.com

Affiliations:
American Public Works Association NY Metro Chapter
NYS Association of Town Superintendents of Highways
Hwy. Superintendents' Association of Rockland County

April 16, 2021

Orietta Trocard, P.E.
NYSDOT Region 8
4 Burnett Boulevard
Poughkeepsie, NY 12603

RE: AWARD DOCUMENTATION
PIN 8780.54: NORTH MIDDLETOWN ROAD PEDESTRIAN LINK: FROM EAST
CENTRAL AVENUE TO BRIGHTWOOD AVENUE
TOWN OF ORANGETOWN, ROCKLAND COUNTY
BID OPENING, ANALYSIS, CERTIFICATION, AND RECOMMENDATION

Dear Ms. Trocard:

In accordance with Chapter 14 of NYSDOT's Local Projects Manual (LPM), the Town of Orangetown has advertised, accepted bids, and completed the award process for the construction contract for the above-referenced locally administered federal aid project including:

- Advertised, at least 15 business days before the bid opening in the NYS Contract Reporter;
- Indicated the Disadvantaged Business Enterprise (DBE) goals in the ad;
- Opened bids and read them aloud in a public forum in accordance with standard competitive bidding procedures and requirements;
- Mathematically verified bids and determined if bids are responsive;
- Provided a tabulation of all bids received at a public bid opening (attached);
- Determined low bidder and, if applicable, the low bidder in accordance with approved alternate bidding procedures, if used;
- Evaluated responsibility of the low bidder in accordance with Section 14.4.1 of the LPM;
- Analyzed bids in accordance with Section 14.4.2 of the LPM (attached);
- Evaluated and ensured appropriate DBE participation by DBE firms listed on NYSDOT registry prior to award;
- Completed all outstanding items, if any, which were incomplete at the time Authorization to Proceed with Advertisement was issued (Right-of-Way, permits, Construction Management Plan, etc.);
- Submitted the Contract Award Documentation Package with the checklist, described in Section 14.7 of the LPM to the RLPL;
- All environmental permits and approvals have been secured except those identified in the contract documents as needing to be obtained and secured by the contractor;

HAMLETS: PEARL RIVER · BLAUVELT · ORANGETOWN · TAPPAN · SPARKILL · PALISADES · UPPER GRANDVIEW



CLEAN STREETS = CLEAN STREAMS

The following information is provided:

- Project authorized for re-advertising by NYSDOT on February 10, 2021
- Project advertised for 21 business days on the NYS Contract Reporter beginning on March 4, 2021
- Project advertised for 22 business days on BidNet beginning on March 3, 2021
- Bid Opening was April 1, 2021
- A Contract Number has not been assigned.
- 5 bids were received;
- 64 plan holders (BidNet), 56 plan holders (NYSCR);
- The computation of bids was verified by: HVEA Engineers on: 4/2/2021
- The construction is being inspected by: HVEA Engineers

Engineer's Estimate: \$ 3,345,000.00 DBE Goal: 10%

Bidders in rank order:

<u>Rank</u>	<u>Bidder Name</u>	<u>Bid Amount</u>
1	Morano Brothers Corp.	\$2,153,064.40
2	Argenio Brothers Inc.	\$2,232,232.00
3	Paladino Concrete Creations	\$2,320,193.60
4	A-Tech Concrete	\$2,838,477.00
5	Con-Tech Construction	\$2,975,927.18

The following irregularities were found: Con-Tech Construction had a few computation errors. This was fixed and is shown in the bid amount above. It did not affect the outcome of the bid.

The Lowest Responsible Bidder: Morano Brothers Corp. Low Bid: \$2,153,064.40

Total Bid	
Federal Share is	\$1,679,000.00
Local Share is	\$538,000.00

- (X) I recommend the award of the above contract to the lowest responsible bidder.
- () I recommend the rejection of all bids.

Very truly yours,

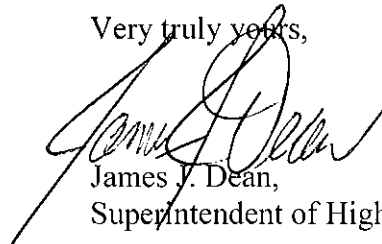

James J. Dean,
Superintendent of Highways

Attachments:
Appendix 14-4, Tabulation of Bids
Bid Analysis

BID OPENING TIME 11:00AM **DATE** April 1, 2021

CONTRACTOR NAME & ADDRESS	A-TECH CONCRETE EDISON NJ					Argenio Bros New Windsor NY					Con-Tech Construction Carmel, NY					MORANO BROS Croton-on-Hudson NY					Paladino Concrete Creations Mt. Vernon NY				
	DATE RECEIVED	4/1/2021					4/1/2021					4/1/2021					4/1/2021					4/1/2021			
TIME RECEIVED	9:11AM					9:56AM					10:03AM					10:09AM					10:19AM				
NON COLLUSION STATEMENT	✓					✓					✓					✓					N/A				
BID BOND or CERTIFIED CHECK	✓					✓					✓					✓					✓				

Item # 201.06 / Estimated Quantity 1 / Clearing and Grubbing / Lump Sum						
Unit Bid Price	\$30000.00	\$500.00	\$6144.00	\$3000.00	\$30,000.00	
Amount Bid Price	\$30000.00	\$500.00	\$6144.00	\$3000.00	\$30,000.00	
Item # 203.02 / Estimated Quantity 1254 / Unclassified Excavation and Disposal / CY						
Unit Bid Price	\$170.00	\$77.00	\$1163.20	\$90.00	\$80.00	
Amount Bid Price	\$213180.00	\$96558.00	\$204652.80	\$112860.00	\$100,320.00	
Item # 203.03 / Estimated Quantity 401 / Embankment in Place / CY						
Unit Bid Price	\$100.00	\$48.00	\$136.00	\$73.00	\$75.00	
Amount Bid Price	\$40100.00	\$19248.00	\$54536.00	\$29273.00	\$30075.00	
Item # 203.07 / Estimated Quantity 117 / Select Granular Fill / CY						
Unit Bid Price	\$140.00	\$130.00	\$128.00	\$38.00	\$90.00	
Amount Bid Price	\$16380.00	\$15210.00	\$14976.00	\$4446.00	\$10,530.00	
Item # 204.01 / Estimated Quantity 40 / Controlled Low Strength Material (CLSM) / CY						
Unit Bid Price	\$420.00	\$200.00	\$220.00	\$148.00	\$125.00	
Amount Bid Price	\$16800.00	\$8000.00	\$8800.00	\$5920.00	\$5,000.00	
Item # 206.0201 / Estimated Quantity 223 / Trench and Culvert Excavation / CY						
Unit Bid Price	\$205.00	\$210.00	\$134.40	\$25.00	\$80.00	
Amount Bid Price	\$45715.00	\$46830.00	\$29971.20	\$5575.00	\$17,840.00	
Item # 206.03 / Estimated Quantity 456 / Conduit Excavation and Backfill Including Surface Restoration / LF						
Unit Bid Price	\$60.00	\$65.00	\$81.25	\$53.00	\$57.50	
Amount Bid Price	\$27360.00	\$29640.00	\$37050.00	\$24168.00	\$26,220.00	
Item # 206.05 / Estimated Quantity 8 / Test Pit Excavation / EA						
Unit Bid Price	\$250.00	\$850.00	\$1600.00	\$920.00	\$500.00	
Amount Bid Price	\$2000.00	\$6800.00	\$12800.00	\$7360.00	\$4,000.00	
Item # 209.100101 / Estimated Quantity 610 / Mulch - Temporary / SY						
Unit Bid Price	\$2.00	\$1.25	\$4.80	\$1.40	\$30.00	
Amount Bid Price	\$1220.00	\$762.50	\$2928.00	\$854.00	\$18,300.00	
Item # 209.1003 / Estimated Quantity 610 / Seed and Mulch - Temporary / SY						
Unit Bid Price	\$2.00	\$145.00	\$9.60	\$1.40	\$1.50	
Amount Bid Price	\$1220.00	\$88450.00	\$5856.00	\$854.00	\$915.00	
Item # 209.11010011 / Estimated Quantity 24 / Temporary Catch Basin Inserts for Drainage Structures Trash, Sediment and Debris Removal / EA						
Unit Bid Price	\$200.00	\$90.00	\$432.00	\$195.00	\$150.00	
Amount Bid Price	\$4800.00	\$2160.00	\$10368.00	\$4680.00	\$3,600.00	
Item # 209.13 / Estimated Quantity 528 / Silt Fence - Temporary / LF						
Unit Bid Price	\$5.00	\$4.00	\$11.20	\$3.60	\$4.00	
Amount Bid Price	\$2640.00	\$2112.00	\$5913.60	\$1900.80	\$2,112.00	

BID OPENING TIME 11:00AM **DATE** April 1, 2021

CONTRACTOR NAME & ADDRESS	A-Tech Concrete		Argento Bros		Cor-Tech Construction		MORNO BROS		Paladino Concrete	
	DATE RECEIVED									
TIME RECEIVED										
NON COLLUSION STATEMENT										
BID BOND or CERTIFIED CHECK										

Item # 304.11000008 / Estimated Quantity 730 / Subbase Course (Modified) / CY										
Unit Bid Price	\$ 115.00	\$ 125.00	\$ 163.20	\$ 128.00	\$ 75.00					
Amount Bid Price	\$83950.00	\$91250.00	\$119136.00	\$93440.00	\$ 54,750.00					
Item # 402.000014 / Estimated Quantity 8 / Plant Production Quality Adjustment to HMA Items / QU										
Unit Bid Price	\$ 105.00	\$ 105.00	\$ 105.00	\$ 105.00	\$ 105.00					
Amount Bid Price	\$ 840.00	\$840.00	\$ 840.00	\$ 840.00	\$ 840.00					
Item # 402.128104 / Estimated Quantity 150 / 12.5 F1 Top Course HMA, 80 Series Compaction / TON										
Unit Bid Price	\$ 290.00	\$ 165.00	\$ 320.00	\$ 140.00	\$ 165.00					
Amount Bid Price	\$43500.00	\$24750.00	\$48000.00	\$21000.00	\$ 24,750.00					
Item # 407.0103 / Estimated Quantity 23 / Straight Tack Coat / Gallon										
Unit Bid Price	\$ 5.00	\$ 20.00	\$ 12.80	\$ 11.00	\$ 12.00					
Amount Bid Price	\$ 115.00	\$ 460.00	\$ 294.40	\$ 253.00	\$ 276.00					
Item # 503.1010 / Estimated Quantity 159 / PCC Foundation for Pavement, Class C / CY										
Unit Bid Price	\$ 400.00	\$ 205.00	\$ 448.00	\$ 208.00	\$ 350.00					
Amount Bid Price	\$63600.00	\$32595.00	\$ 71232.00	\$33072.00	\$ 55650.00					
Item # 522.17 / Estimated Quantity 3044 / Shields and Shoring / SF										
Unit Bid Price	\$ 10.00	\$ 1.00	\$ 11.60	\$ 4.00	\$ 8.00					
Amount Bid Price	\$30440.00	\$3044.00	\$35,310.00	\$12176.00	\$24,352.00					
Item # 602.3615 / Estimated Quantity 760 / Lining with Cured in Place Pipe (CIPP) 15 Inch Diameter / LF										
Unit Bid Price	\$ 80.00	\$ 75.00	\$ 152.00	\$ 80.00	\$ 130.00					
Amount Bid Price	\$60800.00	\$57000.00	\$115,520.00	\$60800.00	\$ 98,800.00					
Item # 602.3618 / Estimated Quantity 103 / Lining with Cured in Place Pipe (CIPP) 18 Inch Diameter / LF										
Unit Bid Price	\$ 255.00	\$ 252.00	\$ 163.20	\$ 265.00	\$ 250.00					
Amount Bid Price	\$26265.00	\$25756.00	\$16809.60	\$27295.00	\$ 25,750.00					
Item # 603.77 / Estimated Quantity 2 / Concrete Collars / EA										
Unit Bid Price	\$ 750.00	\$ 1500.00	\$ 584.00	\$ 1400.00	\$ 1500.00					
Amount Bid Price	\$ 1500.00	\$3000.00	\$1168.00	\$2800.00	\$ 3000.00					
Item # 603.9530 / Estimated Quantity 49 / Ductile Iron Pipe 14 Inch Diameter / LF										
Unit Bid Price	\$ 180.00	\$ 90.00	\$ 152.00	\$ 250.00	\$ 250.00					
Amount Bid Price	\$8820.00	\$4410.00	\$7448.00	\$12250.00	\$ 12,250.00					
Item # 603.9535 / Estimated Quantity 178 / Ductile Iron Pipe 16 Inch Diameter / LF										
Unit Bid Price	\$ 185.00	\$ 85.00	\$ 163.20	\$ 174.00	\$ 300.00					
Amount Bid Price	\$32930.00	\$15130.00	\$29049.60	\$30972.00	\$53400.00					
Item # 603.9540 / Estimated Quantity 50 / Ductile Iron Pipe 18 Inch Diameter / LF										
Unit Bid Price	\$ 215.00	\$ 110.00	\$ 173.60	\$ 270.00	\$ 350.00					
Amount Bid Price	\$10750.00	\$ 5500.00	\$8680.00	\$13500.00	\$17500.00					

BID OPENING TIME 11:00AM **DATE** April 1, 2021

CONTRACTOR NAME & ADDRESS	BID OPENING TIME					DATE														
	<i>A Tech Concrete</i>					<i>Argento Bros</i>														
					<i>Con Tech Construction</i>					<i>Morano Bros</i>										
					<i>Paladino Concrete</i>															
DATE RECEIVED																				
TIME RECEIVED																				
NON COLLUSION STATEMENT																				
BID BOND or CERTIFIED CHECK																				

Item # 603.9815 / Estimated Quantity 12 / Smooth Interior Corrugated Polyethylene Culvert and Storm Drain, 15 Inch Diameter																			
Unit Bid Price	\$ 150.00	\$ 95.00	\$ 184.00	\$ 392.00	\$ 120.00														
Amount Bid Price	\$1800.00	\$1140.00	\$2208.00	\$4704.00	\$1440.00														
Item # 604.070801 / Estimated Quantity 1 / Altering Drainage Structures, Leaching Basins and Manholes / EA																			
Unit Bid Price	\$ 1725.00	\$ 1750.00	\$ 1980.00	\$ 985.00	\$ 2,000.00														
Amount Bid Price	\$ 1725.00	\$ 1750.00	\$ 1980.00	\$ 985.00	\$ 2,000.00														
Item # 604.070802 / Estimated Quantity 1 / Altering Drainage Structures, Leaching Basins and Manholes / EA																			
Unit Bid Price	\$ 1725.00	\$ 1750.00	\$ 1980.00	\$ 985.00	\$ 2,000.00														
Amount Bid Price	\$ 1725.00	\$ 1750.00	\$ 1980.00	\$ 985.00	\$ 2,000.00														
Item # 604.070803 / Estimated Quantity 1 / Altering Drainage Structures, Leaching Basins and Manholes / EA																			
Unit Bid Price	\$ 1725.00	\$ 1750.00	\$ 1980.00	\$ 1400.00	\$ 2,000.00														
Amount Bid Price	\$ 1725.00	\$ 1750.00	\$ 1980.00	\$ 1400.00	\$ 2,000.00														
Item # 604.070804 / Estimated Quantity 1 / Altering Drainage Structures, Leaching Basins and Manholes / EA																			
Unit Bid Price	\$ 1725.00	\$ 1750.00	\$ 1980.00	\$ 985.00	\$ 2,000.00														
Amount Bid Price	\$ 1725.00	\$ 1750.00	\$ 1980.00	\$ 985.00	\$ 2,000.00														
Item # 604.070805 / Estimated Quantity 1 / Altering Drainage Structures, Leaching Basins and Manholes / EA																			
Unit Bid Price	\$ 1725.00	\$ 1750.00	\$ 1980.00	\$ 985.00	\$ 2,000.00														
Amount Bid Price	\$ 1725.00	\$ 1750.00	\$ 1980.00	\$ 985.00	\$ 2,000.00														
Item # 604.070806 / Estimated Quantity 1 / Altering Drainage Structures, Leaching Basins and Manholes / EA																			
Unit Bid Price	\$ 1725.00	\$ 2600.00	\$ 1980.00	\$ 985.00	\$ 2,000.00														
Amount Bid Price	\$ 1725.00	\$ 2600.00	\$ 1980.00	\$ 985.00	\$ 2,000.00														
Item # 604.070807 / Estimated Quantity 1 / Altering Drainage Structures, Leaching Basins and Manhole / EA																			
Unit Bid Price	\$ 1725.00	\$ 2600.00	\$ 1980.00	\$ 1400.00	\$ 2,000.00														
Amount Bid Price	\$ 1725.00	\$ 2600.00	\$ 1980.00	\$ 1400.00	\$ 2,000.00														
Item # 604.070808 / Estimated Quantity 1 / Altering Drainage Structures, Leaching Basins and Manholes / EA																			
Unit Bid Price	\$ 1725.00	\$ 1750.00	\$ 1980.00	\$ 985.00	\$ 2,000.00														
Amount Bid Price	\$ 1725.00	\$ 1750.00	\$ 1980.00	\$ 985.00	\$ 2,000.00														
Item # 604.070809 / Estimated Quantity 1 / Altering Drainage Structures, Leaching Basins and Manholes / EA																			
Unit Bid Price	\$ 1725.00	\$ 1750.00	\$ 1980.00	\$ 985.00	\$ 2,000.00														
Amount Bid Price	\$ 1725.00	\$ 1750.00	\$ 1980.00	\$ 985.00	\$ 2,000.00														
Item # 604.070810 / Estimated Quantity 1 / Altering Drainage Structures, Leaching Basins and Manholes / EA																			
Unit Bid Price	\$ 1725.00	\$ 1750.00	\$ 1980.00	\$ 1400.00	\$ 2,000.00														
Amount Bid Price	\$ 1725.00	\$ 1750.00	\$ 1980.00	\$ 1400.00	\$ 2,000.00														
Item # 604.070811 / Estimated Quantity 1 / Altering Drainage Structures, Leaching Basins and Manholes / EA																			
Unit Bid Price	\$ 1725.00	\$ 1750.00	\$ 1980.00	\$ 985.00	\$ 2,000.00														
Amount Bid Price	\$ 1725.00	\$ 1750.00	\$ 1980.00	\$ 985.00	\$ 2,000.00														

BID OPENING TIME 11:00AM **DATE** April 1, 2021

CONTRACTOR NAME & ADDRESS	A-Tech Concrete					Argento Bros					A-Tech Construction					Morano Bros					Paladino Concrete				
	DATE RECEIVED																								
TIME RECEIVED																									
NON COLLUSION STATEMENT																									
BID BOND or CERTIFIED CHECK																									

Item # 604.070812 / Estimated Quantity 1 / Altering Drainage Structures, Leaching Basins and Manholes / EA																										
Unit Bid Price	\$1725.00	\$1750.00	\$1980.00	\$985.00	\$2,000.00																					
Amount Bid Price	\$1725.00	\$1750.00	\$1980.00	\$985.00	\$2,000.00																					
Item # 604.070813 / Estimated Quantity 1 / Altering Drainage Structures, Leaching Basins and Manholes / EA																										
Unit Bid Price	\$1725.00	\$1750.00	\$1980.00	\$1400.00	\$2,000.00																					
Amount Bid Price	\$1725.00	\$1750.00	\$1980.00	\$1400.00	\$2,000.00																					
Item # 604.070814 / Estimated Quantity 1 / Altering Drainage Structures, Leaching Basins and Manholes / EA																										
Unit Bid Price	\$1725.00	\$1750.00	\$1980.00	\$985.00	\$2,000.00																					
Amount Bid Price	\$1725.00	\$1750.00	\$1980.00	\$985.00	\$2,000.00																					
Item # 604.07290010 / Estimated Quantity 90 / Repair Walls of Existing Drainage Structures / SF																										
Unit Bid Price	\$25.00	\$100.00	\$42.40	\$50.00	\$100.00																					
Amount Bid Price	\$2250.00	\$9000.00	\$3816.00	\$4500.00	\$9000.00																					
Item # 604.300273 / Estimated Quantity 5 / Rectangular Drainage Structure Type B for Cast F3 Frame / LF																										
Unit Bid Price	\$900.00	\$450.00	\$1224.00	\$1380.00	\$1,000.00																					
Amount Bid Price	\$4500.00	\$2250.00	\$6120.00	\$6900.00	\$5,000.00																					
Item # 604.301873 / Estimated Quantity 28 / Rectangular Drainage Structure Type R for Cast Iron F3 Frame / LF																										
Unit Bid Price	\$750.00	\$390.00	\$1184.00	\$950.00	\$1,000.00																					
Amount Bid Price	\$2100.00	\$10920.00	\$33152.00	\$26600.00	\$28,000.00																					
Item # 604.302122 / Estimated Quantity 7 / Rectangular Drainage Structure Type U for #22 Welded Frame / LF																										
Unit Bid Price	\$850.00	\$350.00	\$1408.00	\$790.00	\$1,000.00																					
Amount Bid Price	\$5950.00	\$2450.00	\$9856.00	\$5530.00	\$7,000.00																					
Item # 604.4060 / Estimated Quantity 6 / Round Precast Concrete Manhole Type 60 / LF																										
Unit Bid Price	\$800.00	\$1050.00	\$1744.00	\$1100.00	\$750.00																					
Amount Bid Price	\$4800.00	\$6300.00	\$10464.00	\$6600.00	\$4500.00																					
Item # 608.0101 / Estimated Quantity 226 / Concrete Sidewalks and Driveways / CY																										
Unit Bid Price	\$875.00	\$575.00	\$880.00	\$770.00	\$825.00																					
Amount Bid Price	\$197750.00	\$129950.00	\$198880.00	\$174120.00	\$186,450.00																					
Item # 608.01020005 / Estimated Quantity 71 / Colored and Imprinted Portland Cement Concrete Sidewalk / CY																										
Unit Bid Price	\$1250.00	\$1200.00	\$1600.00	\$1200.00	\$1100.00																					
Amount Bid Price	\$88750.00	\$85200.00	\$113600.00	\$85200.00	\$78100.00																					
Item # 608.03 / Estimated Quantity 21 / Brick Paved Sidewalk and Driveways (Sand Setting Bed) / SY																										
Unit Bid Price	\$600.00	\$250.00	\$168.00	\$288.00	\$120.00																					
Amount Bid Price	\$12600.00	\$5250.00	\$3528.00	\$6048.00	\$2520.00																					
Item # 608.20 / Estimated Quantity 2 / Surface Applied Detectable Warning Units / SY																										
Unit Bid Price	\$1100.00	\$375.00	\$1344.00	\$380.00	\$400.00																					
Amount Bid Price	\$2200.00	\$750.00	\$2688.00	\$760.00	\$800.00																					

BID OPENING TIME 11:00AM **DATE** April 1, 2021

CONTRACTOR NAME & ADDRESS	A-Tech Concrete					Argonio Bros					Com-Tech Construction					Morano Bros					Palumbo Concrete				
DATE RECEIVED																									
TIME RECEIVED																									
NON COLLUSION STATEMENT																									
BID BOND or CERTIFIED CHECK																									

Item # 608.21 / Estimated Quantity 99 / Embedded Detectable Warning Units / SY																	
Unit Bid Price	\$ 425.00	\$ 315.00	\$ 825.00	\$ 350.00	\$ 400.00												
Amount Bid Price	\$42075.00	\$31185.00	\$81675.00	\$34650.00	\$39600.00												
Item # 609.0401 / Estimated Quantity 4094 / Cast-In-Place Concrete Curb Type VF150 / LF																	
Unit Bid Price	\$ 28.00	\$ 28.00	\$ 58.40	\$ 30.00	\$ 39.00												
Amount Bid Price	\$114632.00	\$114632.00	\$239,089.00	\$122820.00	\$159600.00												
Item # 609.0407 / Estimated Quantity 815 / Cast-In-Place Concrete Curb Type T100 / LF																	
Unit Bid Price	\$ 40.00	\$ 32.00	\$ 68.00	\$ 35.00	\$ 45.00												
Amount Bid Price	\$32600.00	\$26080.00	\$55420.00	\$28525.00	\$36675.00												
Item # 609.15 / Estimated Quantity 364 / Resetting Existing Curb / LF																	
Unit Bid Price	\$ 50.00	\$ 28.00	\$ 56.00	\$ 37.00	\$ 25.00												
Amount Bid Price	\$18200.00	\$10192.00	\$20384.00	\$13468.00	\$9100.00												
Item # 610.1101 / Estimated Quantity 11 / Mulch for Planting Type A, B & D - Wood Chips and Shredded Bark / CY																	
Unit Bid Price	\$ 12.00	\$ 170.00	\$ 7.60	\$ 10.00	\$ 75.00												
Amount Bid Price	\$132.00	\$1870.00	\$83.60	\$110.00	\$825.00												
Item # 610.1403 / Estimated Quantity 69 / Topsoil - Lawns / CY																	
Unit Bid Price	\$ 170.00	\$ 110.00	\$ 150.40	\$ 90.00	\$ 65.00												
Amount Bid Price	\$11730.00	\$7590.00	\$10372.60	\$6210.00	\$4485.00												
Item # 610.16010020 / Estimated Quantity 610 / Turf Establishment - Performance / SY																	
Unit Bid Price	\$ 4.00	\$ 7.00	\$ 12.00	\$ 3.60	\$ 1.50												
Amount Bid Price	\$2440.00	\$4270.00	\$7320.00	\$2196.00	\$915.00												
Item # 611.0193 / Estimated Quantity 6 / Planting - Major Deciduous Trees - 4 Inch Caliper Bareroot / EA																	
Unit Bid Price	\$ 2000.00	\$ 600.00	\$ 1520.00	\$ 1600.00	\$ 1900.00												
Amount Bid Price	\$12000.00	\$3600.00	\$9120.00	\$9600.00	\$11400.00												
Item # 611.10 / Estimated Quantity 1 / Transplanting 0 - 48 Inch in Height / EA																	
Unit Bid Price	\$ 550.00	\$ 250.00	\$ 1096.00	\$ 320.00	\$ 1500.00												
Amount Bid Price	\$ 550.00	\$ 250.00	\$ 1096.00	\$ 320.00	\$ 1500.00												
Item # 614.060104 / Estimated Quantity 6 / Tree Removal over 4 Inches to 6 Inches Diameter Breast Height Stumps Grubbed / EA																	
Unit Bid Price	\$ 1500.00	\$ 300.00	\$ 776.00	\$ 620.00	\$ 400.00												
Amount Bid Price	\$9000.00	\$1800.00	\$4656.00	\$3720.00	\$2400.00												
Item # 619.01 / Estimated Quantity 1 / Basic Work Zone Traffic Control / Lump Sum																	
Unit Bid Price	\$450000.00	\$367,500.00	\$264000.00	\$65000.00	\$75000.00												
Amount Bid Price	\$450000.00	\$367,500.00	\$264000.00	\$65000.00	\$75000.00												
Item # 619.04 / Estimated Quantity 20 / Type III Construction Barricade / EA																	
Unit Bid Price	\$ 55.00	\$ 50.00	\$ 264.00	\$ 170.00	\$ 200.00												
Amount Bid Price	\$1100.00	\$1000.00	\$5280.00	\$3400.00	\$4000.00												

BID OPENING TIME 11:00AM **DATE** April 1, 2021

CONTRACTOR NAME & ADDRESS	A-Tech Concrete					Argento Bros					Con-Tech Construction					Morano Bros					Paladino Concrete				
DATE RECEIVED																									
TIME RECEIVED																									
NON COLLUSION STATEMENT																									
BID BOND or CERTIFIED CHECK																									

Item # 619.080102 / Estimated Quantity 1426 / Remove Pavement Marking Stripes, Epoxy Paint / LF

Unit Bid Price	\$ 2.00	\$ 1.00	\$ 1.13	\$ 1.00	\$ 1.75	X
Amount Bid Price	\$2852.00	\$1426.00	\$1604.25	\$1426.00	\$2495.50	

Item # 619.080202 / Estimated Quantity 18 / Remove Pavement Marking Letters or Symbols, Epoxy Paint / EA

Unit Bid Price	\$ 65.00	\$ 100.00	\$ 125.00	\$ 105.00	\$ 90.00	X
Amount Bid Price	\$1170.00	\$1800.00	\$2250.00	\$1890.00	\$1620.00	

Item # 619.080106 / Estimated Quantity 281 / Remove Pavement Marking Stripes - Permanent Pavement Tape / LF

Unit Bid Price	\$ 3.00	\$ 1.00	\$ 1.88	\$ 1.00	\$ 3.50	X
Amount Bid Price	\$ 843.00	\$281.00	\$526.88	\$281.00	\$983.50	

Item # 619.0803 / Estimated Quantity 43 / Cover Existing Pavement Marking Stripes (Removable Tape) / LF

Unit Bid Price	\$ 10.00	\$ 4.00	\$ 3.75	\$ 4.00	\$ 7.00	X
Amount Bid Price	\$ 430.00	\$ 172.00	\$ 161.25	\$ 172.00	\$ 301.00	

Item # 619.0804 / Estimated Quantity 12 / Cover Existing Pavement Marking Letters or Symbols (Removable Tape) / EA

Unit Bid Price	\$ 125.00	\$ 175.00	\$ 143.75	\$ 185.00	\$ 200.00	X
Amount Bid Price	\$ 1500.00	\$ 2100.00	\$ 1725.00	\$ 2220.00	\$ 2400.00	

Item # 619.100104 / Estimated Quantity 6488 / Interim Pavement Markings, Stripes (Removable Wet Reflective Tape) / LF

Unit Bid Price	\$ 2.00	\$ 2.75	\$ 4.06	\$ 3.00	\$ 3.75	X
Amount Bid Price	\$12976.00	\$17842.00	\$26357.50	\$19464.00	\$24330.00	

Item # 619.100204 / Estimated Quantity 3 / Interim Pavement Markings, Symbols (Removable Wet Reflective Tape) / EA

Unit Bid Price	\$ 3.00	\$ 150.00	\$ 187.50	\$ 160.00	\$ 350.00	X
Amount Bid Price	\$ 900.00	\$ 450.00	\$ 562.50	\$ 480.00	\$ 1050.00	

Item # 619.1612 / Estimated Quantity 4 / Maintain Traffic Signal Equipment (Requirement B) / Intersection Month

Unit Bid Price	\$ 500.00	\$ 400.00	\$ 500.00	\$ 2700.00	\$ 288.00	X
Amount Bid Price	\$2000.00	\$ 1600.00	\$2000.00	\$10800.00	\$ 1152.00	

Item # 621.03 / Estimated Quantity 240 / Cleaning Closed Drainage Systems / LF

Unit Bid Price	\$ 15.00	\$ 12.00	\$ 9.28	\$ 16.00	\$ 10.20	X
Amount Bid Price	\$3600.00	\$2880.00	\$2227.20	\$3840.00	\$2448.00	

Item # 621.04 / Estimated Quantity 17 / Cleaning Drainage Structures / EA

Unit Bid Price	\$ 600.00	\$ 600.00	\$ 196.00	\$ 725.00	\$ 198.00	X
Amount Bid Price	\$10200.00	\$10200.00	\$3332.00	\$12325.00	\$3366.00	

Item # 623.12000008 / Estimated Quantity 3 / Crushed Stone (In Place Measure) Modified / CY

Unit Bid Price	\$ 115.00	\$ 285.00	\$ 164.00	\$ 225.00	\$ 90.00	X
Amount Bid Price	\$345.00	\$855.00	\$492.00	\$675.00	\$270.00	

BID OPENING TIME 11:00AM **DATE** April 1, 2021

CONTRACTOR NAME & ADDRESS	A-Tech Concrete					Argemid Bros					ConTech Construction					Morano Bros					Paladino Concrete				
	DATE RECEIVED																								
TIME RECEIVED																									
NON COLLUSION STATEMENT																									
BID BOND or CERTIFIED CHECK																									

Item # 625.01 / Estimated Quantity 1 / Survey Operations / Lump Sum						
Unit Bid Price	\$60,000.00	\$21,700.00	\$14,000.00	\$80,000.00	\$40,000.00	
Amount Bid Price	\$60,000.00	\$21,700.00	\$14,000.00	\$80,000.00	\$40,000.00	
Item # 627.50140008 / Estimated Quantity 5240 / Cutting Pavement / LF						
Unit Bid Price	\$ 1.00	\$ 4.00	\$ 7.68	\$ 3.30	\$ 5.00	
Amount Bid Price	\$5240.00	\$20960.00	\$40243.20	\$17292.00	\$26200.00	
Item # 637.12 / Estimated Quantity 8 / Engineer's Field Office - Type 2 / Calendar Month						
Unit Bid Price	\$8000.00	\$4500.00	\$4864.00	\$6900.00	\$3000.00	
Amount Bid Price	\$64000.00	\$36000.00	\$38912.00	\$55200.00	\$24000.00	
Item # 637.34 / Estimated Quantity 5000 / Office Technology and Supplies / Dollars and Cents						
Unit Bid Price	\$1.00	\$1.00	\$1.00	\$1.00	\$1.00	
Amount Bid Price	\$5,000.00	\$5,000.00	\$5,000.00	\$5,000.00	\$5,000.00	
Item # 637.36 / Estimated Quantity 100 / Construction Testing Supplies - Consumables / Dollars and Cents						
Unit Bid Price	\$1.00	\$1.00	\$1.00	\$1.00	\$1.00	
Amount Bid Price	\$100.00	\$100.00	\$100.00	\$100.00	\$100.00	
Item # 645.5101 / Estimated Quantity 9 / Ground - Mounted Sign Panels Without Z-Bars / SF						
Unit Bid Price	\$ 30.00	\$ 150.00	\$124.80	\$ 69.00	\$ 130.00	
Amount Bid Price	\$270.00	\$1350.00	\$1623.20	\$621.00	\$1170.00	
Item # 645.5102 / Estimated Quantity 4 / Ground - Mounted Sign Panels Less than or Equal to 30 SF with Z-Bars / SF						
Unit Bid Price	\$ 30.00	\$ 175.00	\$144.00	\$ 80.00	\$ 170.00	
Amount Bid Price	\$ 120.00	\$ 700.00	\$576.00	\$320.00	\$ 680.00	
Item # 645.5202 / Estimated Quantity 134 / Ground - Mounted Sign Panels Less than or Equal to 30 SF with Z-Bars, High - Visibility Sheeting / SF						
Unit Bid Price	\$ 20.00	\$ 70.00	\$ 152.00	\$ 80.00	\$ 170.00	
Amount Bid Price	\$2680.00	\$9380.00	\$20368.00	\$10720.00	\$22780.00	
Item # 645.61 / Estimated Quantity 23 / Overhead Sign Panels / SF						
Unit Bid Price	\$ 400.00	\$ 300.00	\$ 375.00	\$ 80.00	\$ 170.00	
Amount Bid Price	\$9200.00	\$6900.00	\$8625.00	\$1840.00	\$3910.00	
Item # 645.81 / Estimated Quantity 35 / Type A Sign Posts / EA						
Unit Bid Price	\$ 375.00	\$ 325.00	\$ 256.00	\$370.00	\$ 295.00	
Amount Bid Price	\$13125.00	\$11375.00	\$8960.00	\$12950.00	\$10325.00	
Item # 645.81020003 / Estimated Quantity 13 / Retroreflective Sign Post Strip / EA						
Unit Bid Price	\$ 100.00	\$ 80.00	\$ 288.00	\$ 160.00	\$ 54.00	
Amount Bid Price	\$ 1300.00	\$1040.00	\$3744.00	\$2080.00	\$ 702.00	

BID OPENING TIME 11:00AM **DATE** April 1, 2021

CONTRACTOR NAME & ADDRESS	<i>A-Tech Concrete</i>	<i>Argento Bros</i>	<i>Con-Tech Construction</i>	<i>Morano Bros</i>	<i>Paladino Concrete</i>
DATE RECEIVED					
TIME RECEIVED					
NON COLLUSION STATEMENT					
BID BOND or CERTIFIED CHECK					

Item # 647.31 / Estimated Quantity 29 /Relocate Sign Panel, Sign Panel Assembly Size I (Under 30 Square Feet)/EA

Unit Bid Price	\$ 150.00	\$ 250.00	\$ 352.00	\$ 265.00	\$ 460.00	
Amount Bid Price	\$4350.00	\$7250.00	\$10208.00	\$7685.00	\$13340.00	

Item # 647.61 / Estimated Quantity 17 / Remove and Dispose Signs, Ground Mounted Type A Sign Supports and Foundations - Size I (Under 30 Square Feet) / EA

Unit Bid Price	\$ 250.00	\$ 75.00	\$ 192.00	\$ 265.00	\$ 115.00	
Amount Bid Price	\$4250.00	\$1275.00	\$3264.00	\$4505.00	\$1955.00	

Item # 655.05010010 / Estimated Quantity 2 /Resetting Existing Sanitary Sewer Manhole Castings / EA

Unit Bid Price	\$ 600.00	\$ 950.00	\$2320.00	\$ 882.00	\$ 750.00	
Amount Bid Price	\$1200.00	\$1900.00	\$4640.00	\$1764.00	\$1500.00	

Item # 655.0706 / Estimated Quantity 6 /Cast Frame F3, Unmountable Curb Box CU3 & Reticuline Grate G3 / EA

Unit Bid Price	\$3000.00	\$ 1800.00	\$5504.00	\$3000.00	\$2500.00	
Amount Bid Price	\$18000.00	\$10800.00	\$33024.00	\$18000.00	\$15000.00	

Item # 655.1122 / Estimated Quantity 1 / Welded Frame and Reticuline Grate 22 / EA

Unit Bid Price	\$2000.00	\$ 1500.00	\$3264.00	\$ 1700.00	\$ 2500.00	
Amount Bid Price	\$2000.00	\$1500.00	\$3264.00	\$1700.00	\$2500.00	

Item # 655.1201 / Estimated Quantity 2 / Manhole Frame and Grate / EA

Unit Bid Price	\$ 1250.00	\$ 1350.00	\$ 2208.00	\$ 1400.00	\$ 2500.00	
Amount Bid Price	\$2500.00	\$2700.00	\$4416.00	\$2800.00	\$5000.00	

Item # 662.60030008. / Estimated Quantity 1 /Altering Elevation of Gas Valve Boxes / EA

Unit Bid Price	\$ 400.00	\$ 100.00	\$1200.00	\$ 200.00	\$ 100.00	
Amount Bid Price	\$ 400.00	\$ 100.00	\$1200.00	\$ 200.00	\$100.00	

Item # 662.60510008 / Estimated Quantity 3 /Adjust Manhole to Grade (Telephone) / EA

Unit Bid Price	\$ 1000.00	\$ 1800.00	\$1200.00	\$ 1400.00	\$ 250.00	
Amount Bid Price	\$3000.00	\$5400.00	\$3600.00	\$4200.00	\$750.00	

Item # 663.33 / Estimated Quantity 1 /Adjust Existing Valve Box Elevation / EA

Unit Bid Price	\$ 500.00	\$ 150.00	\$920.00	\$200.00	\$ 100.00	
Amount Bid Price	\$ 500.00	\$ 150.00	\$920.00	\$200.00	\$ 100.00	

Item # 670.14480010/ Estimated Quantity 1 /Resetting Electric Pullbox Covers and Frames / EA

Unit Bid Price	\$ 1000.00	\$ 800.00	\$1000.00	\$ 530.00	\$ 250.00	
Amount Bid Price	\$1000.00	\$ 800.00	\$1000.00	\$530.00	\$250.00	

Item # 680.5001/ Estimated Quantity 24 /Pole Excavation and Concrete Foundation / CY

Unit Bid Price	\$ 4000.00	\$ 3000.00	\$3750.00	\$3000.00	\$ 3163.00	
Amount Bid Price	\$96000.00	\$72000.00	\$90000.00	\$72000.00	\$75912.00	

Item # 680.510501/ Estimated Quantity 8 / Pullbox - Rectangular, 26 x 18 Inch, Reinforced Concrete / EA

Unit Bid Price	\$2000.00	\$ 1500.00	\$ 1875.00	\$ 1600.00	\$1656.00	
Amount Bid Price	\$16000.00	\$12000.00	\$15000.00	\$12800.00	\$13248.00	

BID OPENING TIME	<u>11:00AM</u>	DATE	<u>April 1, 2021</u>
-------------------------	----------------	-------------	----------------------

CONTRACTOR NAME & ADDRESS	<i>A-Tech Concrete Edison NJ</i>	<i>Argenio Bros New Windsor</i>	<i>Con-Tech Construction Carmel, NY</i>	<i>Morano Bros Lorton, Va-Hudson</i>	<i>Paladino Concrete Mt. Vernon, NY</i>
--------------------------------------	--------------------------------------	-------------------------------------	---	--	---

DATE RECEIVED						X
TIME RECEIVED						
NON COLLUSION STATEMENT						
BID BOND or CERTIFIED CHECK						

Item # 680.520106 / Estimated Quantity 343 / Conduit, Metal, Steel, Zinc Coated, 2" / LF

Unit Bid Price	\$ 25.00	\$ 20.00	\$ 25.00	\$ 26.00	\$ 29.00	X
Amount Bid Price	\$ 8575.00	\$ 6860.00	\$ 8575.00	\$ 8918.00	\$ 9947.00	

Item # 680.520108 / Estimated Quantity 113 / Conduit, Metal Steel, Zinc Coated, 3" / LF

Unit Bid Price	\$ 50.00	\$ 35.00	\$ 43.75	\$ 40.00	\$ 44.00	X
Amount Bid Price	\$ 5650.00	\$ 3955.00	\$ 4943.75	\$ 4520.00	\$ 4972.00	

Item # 680.520110 / Estimated Quantity 2 / Conduit, Metal Steel, Zinc Coated, 4"

Unit Bid Price	\$ 900.00	\$ 600.00	\$ 750.00	\$ 75.00	\$ 81.00	X
Amount Bid Price	\$ 1800.00	\$ 1200.00	\$ 1500.00	\$ 150.00	\$ 162.00	

Item # 680.621950 / Estimated Quantity 1 / Traffic Signal Pole, Mast Arm, 19 Feet Mounting Height, 50 Feet Arm Length / EA

Unit Bid Price	\$ 18000.00	\$ 13000.00	\$ 16250.00	\$ 17000.00	\$ 18285.00	X
Amount Bid Price	\$ 18000.00	\$ 13000.00	\$ 16250.00	\$ 17000.00	\$ 18285.00	

Item # 680.631940 / Estimated Quantity 1 / Traffic Signal Pole, Dual Mast Arm, 19 Feet Mounting Height, 40 Feet Arm Length / EA

Unit Bid Price	\$ 16500.00	\$ 12000.00	\$ 15000.00	\$ 17000.00	\$ 17653.00	X
Amount Bid Price	\$ 16500.00	\$ 12000.00	\$ 15000.00	\$ 17000.00	\$ 17653.00	

Item # 680.730514 / Estimated Quantity 2072 / Signal Cable 5 Conductors, 14 AWG / LF

Unit Bid Price	\$ 15.00	\$ 12.00	\$ 15.00	\$ 5.00	\$ 6.00	X
Amount Bid Price	\$ 31080.00	\$ 24864.00	\$ 31080.00	\$ 10360.00	\$ 12432.00	

Item # 680.79010008 / Estimated Quantity 1 / Remove Traffic Signal Equipment / Lump Sum

Unit Bid Price	\$ 5000.00	\$ 4000.00	\$ 5,000.00	\$ 5800.00	\$ 6325.00	X
Amount Bid Price	\$ 5000.00	\$ 4000.00	\$ 5,000.00	\$ 5800.00	\$ 6325.00	

Item # 680.80310008 / Estimated Quantity 2 / Furnish and Install Microcomputer (Model 2070) Complete with Stretch - Type Cabinet / EA

Unit Bid Price	\$ 25000.00	\$ 16000.00	\$ 23750.00	\$ 18000.00	\$ 19895.00	X
Amount Bid Price	\$ 50000.00	\$ 32000.00	\$ 47500.00	\$ 76000.00	\$ 39,790.00	

Item # 680.810101 / Estimated Quantity 14 / Traffic Signal Module - 12 Inch, Red Ball, LED / EA

Unit Bid Price	\$ 150.00	\$ 125.00	\$ 156.25	\$ 145.00	\$ 155.00	X
Amount Bid Price	\$ 2100.00	\$ 1750.00	\$ 2187.50	\$ 2030.00	\$ 2170.00	

Item # 680.810103 / Estimated Quantity 14 / Traffic Signal Module - 12 Inch, Yellow Ball, LED / EA

Unit Bid Price	\$ 150.00	\$ 125.00	\$ 156.25	\$ 145.00	\$ 155.00	X
Amount Bid Price	\$ 2100.00	\$ 1750.00	\$ 2187.50	\$ 2030.00	\$ 2170.00	

Item # 680.810104 / Estimated Quantity 3 / Traffic Signal Module - 12 Inch, Yellow Arrow, LED / EA

Unit Bid Price	\$ 200.00	\$ 125.00	\$ 156.25	\$ 145.00	\$ 155.00	X
Amount Bid Price	\$ 600.00	\$ 375.00	\$ 468.75	\$ 435.00	\$ 450.00	

BID OPENING TIME 11:00AM **DATE** April 1, 2021

CONTRACTOR NAME & ADDRESS	A-Tech Concrete					Argenio Bros					Con-Tech Construction					Morano Bros					Paladino Concrete				
DATE RECEIVED																									
TIME RECEIVED																									
NON COLLUSION STATEMENT																									
BID BOND or CERTIFIED CHECK																									

Item # 680.810105 / Estimated Quantity 14 / Traffic Signal Module - 12 Inch, Green Ball, LED / EA																
Unit Bid Price	\$ 155.00	\$ 125.00	\$ 156.25	\$ 145.00	\$ 155.00											
Amount Bid Price	\$2170.00	\$ 1750.00	\$2187.50	\$2030.00	\$2170.00											
Item # 680.810106 / Estimated Quantity 3 / Traffic Signal Module - 12 Inch, Green Arrow, LED / EA																
Unit Bid Price	\$ 200.00	\$ 125.00	\$ 156.25	\$ 145.00	\$ 155.00											
Amount Bid Price	\$600.00	\$ 1750.00	\$468.75	\$ 435.00	\$465.00											
Item # 680.810107 / Estimated Quantity 48 / Traffic Signal Section - Type I, 12 Inch / EA																
Unit Bid Price	\$ 250.00	\$ 200.00	\$ 250.00	\$ 291.00	\$ 315.00											
Amount Bid Price	\$1200.00	\$960.00	\$1200.00	\$139108.00	\$15120.00											
Item # 680.8111 / Estimated Quantity 4 / Traffic Signal Bracket Assembly - 1 Way/ EA																
Unit Bid Price	\$ 400.00	\$ 300.00	\$ 375.00	\$ 585.00	\$ 633.00											
Amount Bid Price	\$1600.00	\$ 1200.00	\$ 1500.00	\$2340.00	\$2532.00											
Item # 680.81230008 / Estimated Quantity 2 / Traffic Signal Bracket Assembly - 1 Way Mast Arm Mount (Cable Type) EA																
Unit Bid Price	\$ 600.00	\$ 425.00	\$ 531.25	\$ 595.00	\$ 644.00											
Amount Bid Price	\$1200.00	\$850.00	\$1062.50	\$1190.00	\$1288.00											
Item # 680.81240008 / Estimated Quantity 4 / Traffic Signal Bracket Assembly - 2 Way Mast Arm Mount (Cable Type) / EA																
Unit Bid Price	\$ 700.00	\$ 525.00	\$ 656.25	\$ 690.00	\$ 748.00											
Amount Bid Price	\$2800.00	\$2100.00	\$2625.00	\$2760.00	\$2992.00											
Item # 680.81310109 / Estimated Quantity 11 / Accessible Pedestrian Signal (APS) with Pole / EA																
Unit Bid Price	\$ 3000.00	\$ 2200.00	\$ 2750.00	\$ 2200.00	\$ 2358.00											
Amount Bid Price	\$33000.00	\$24200.00	\$30250.00	\$24200.00	\$25938.00											
Item # 680.81310209 / Estimated Quantity 3 / Accessible Pedestrian Signal (APS) without Pole/ EA																
Unit Bid Price	\$ 1250.00	\$ 1000.00	\$ 1250.00	\$ 1300.00	\$ 1380.00											
Amount Bid Price	\$3750.00	\$ 3000.00	\$3750.00	\$3900.00	\$4140.00											
Item # 680.813103 / Estimated Quantity 28 / Pedestrian Signal Section - Type I, 12 Inch / EA																
Unit Bid Price	\$ 150.00	\$ 125.00	\$ 156.25	\$ 415.00	\$ 449.00											
Amount Bid Price	\$4200.00	\$3500.00	\$4375.00	\$11620.00	\$12572.00											
Item # 680.813105 / Estimated Quantity 14 / Pedestrian Signal Module - 12 Inch Bi-Modal, Hand /Man Symbols LED / EA																
Unit Bid Price	\$ 200.00	\$ 150.00	\$ 187.50	\$ 400.00	\$ 436.00											
Amount Bid Price	\$2800.00	\$2100.00	\$2625.00	\$5600.00	\$6034.00											
Item # 680.8141 / Estimated Quantity 14 / Pedestrian Signal Bracket - Mount Assembly / EA																
Unit Bid Price	\$ 200.00	\$ 160.00	\$ 200.00	\$ 400.00	\$ 437.00											
Amount Bid Price	\$2800.00	\$2240.00	\$2800.00	\$5600.00	\$6118.00											

BID ITEM

North Middletown Road Pedestrian Link
East Central Ave to Brightwood Ave - PIN. 8780.54

SHEET 11 OF 12

BID OPENING TIME

11:00AM

DATE

April 1, 2021

CONTRACTOR NAME & ADDRESS

A-Tech Concrete

Argenio Bros

Con-Tech Construction

Morano Bros

Paladino Concrete

DATE RECEIVED

TIME RECEIVED

NON COLLUSION STATEMENT

BID BOND or CERTIFIED CHECK

Item # 680.81500010 / Estimated Quantity 14 / Pedestrian Count - Down Timer Module / EA						
Unit Bid Price	\$ 300.00	\$ 220.00	\$ 275.00	\$ 400.00	\$ 431.00	
Amount Bid Price	\$ 4200.00	\$ 3080.00	\$ 3850.00	\$ 5600.00	\$ 6034.00	
Item # 680.81980010 / Estimated Quantity 14 / Traffic Signal Backplates with Yellow Reflective Tape / EA						
Unit Bid Price	\$ 400.00	\$ 300.00	\$ 375.00	\$ 315.00	\$ 340.00	
Amount Bid Price	\$ 5600.00	\$ 4200.00	\$ 5250.00	\$ 4410.00	\$ 4760.00	
Item # 680.8205 / Estimated Quantity 1 / Overhead Sign Assembly, Type E/ EA						
Unit Bid Price	\$ 1000.00	\$ 800.00	\$ 1000.00	\$ 740.00	\$ 800.00	
Amount Bid Price	\$ 1000.00	\$ 800.00	\$ 1000.00	\$ 740.00	\$ 800.00	
Item # 680.8206 / Estimated Quantity 2 / Overhead Sign Assembly, Type F/ EA						
Unit Bid Price	\$ 1000.00	\$ 800.00	\$ 1000.00	\$ 770.00	\$ 834.00	
Amount Bid Price	\$ 2000.00	\$ 1600.00	\$ 2000.00	\$ 1540.00	\$ 1668.00	
Item # 680.82201908 / Estimated Quantity 11 / Breakaway Transformer Base (Traffic) EA						
Unit Bid Price	\$ 900.00	\$ 700.00	\$ 875.00	\$ 765.00	\$ 828.00	
Amount Bid Price	\$ 9900.00	\$ 7700.00	\$ 9625.00	\$ 8415.00	\$ 9108.00	
Item # 680.82254310 / Estimated Quantity 8 / Rectangular Rapid Flashing Beacon (RRFB) Assembly - Four Beacons, Solar Powered/ EA						
Unit Bid Price	\$ 7500.00	\$ 5825.00	\$ 7250.00	\$ 16000.00	\$ 16675.00	
Amount Bid Price	\$ 60000.00	\$ 46600.00	\$ 58000.00	\$ 128000.00	\$ 133400.00	
Item # 680.94000008 / Estimated Quantity 2 / Traffic Signal Service Entrance /EA						
Unit Bid Price	\$ 2000.00	\$ 1500.00	\$ 1875.00	\$ 1300.00	\$ 1380.00	
Amount Bid Price	\$ 4000.00	\$ 3000.00	\$ 3750.00	\$ 2600.00	\$ 2760.00	
Item # 680.94980307 / Estimated Quantity 1 / Video Vehicle Presence Detector System / EA						
Unit Bid Price	\$ 40000.00	\$ 28150.00	\$ 37500.00	\$ 33000.00	\$ 34983.00	
Amount Bid Price	\$ 40000.00	\$ 28150.00	\$ 37500.00	\$ 33000.00	\$ 34983.00	
Item # 680.94980407 / Estimated Quantity 1 / Video Vehicle Presence Detector System / EA						
Unit Bid Price	\$ 40000.00	\$ 28150.00	\$ 37500.00	\$ 33000.00	\$ 34983.00	
Amount Bid Price	\$ 40000.00	\$ 28150.00	\$ 37500.00	\$ 33000.00	\$ 34983.00	
Item #680.94997008 / Estimated Quantity 2 / Furnish and Install Electrical Disconnect Generator Transfer Switch/EA						
Unit Bid Price	\$ 2000.00	\$ 1520.00	\$ 1875.00	\$ 1300.00	\$ 1438.00	
Amount Bid Price	\$ 4000.00	\$ 3000.00	\$ 3750.00	\$ 2600.00	\$ 2876.00	
Item #680.95020615 / Estimated Quantity 276 / Service Cable 2 Conductor NO. 06 AWG / LF						
Unit Bid Price	\$ 12.00	\$ 10.00	\$ 12.50	\$ 5.00	\$ 6.00	
Amount Bid Price	\$ 3312.00	\$ 2760.00	\$ 3450.00	\$ 1380.00	\$ 1656.00	
Item #685.01 / Estimated Quantity 9458 / White Epoxy Reflectorized Pavement Stripes - 15 MILS /LF						
Unit Bid Price	\$ 1.00	\$ 1.25	\$ 1.56	\$ 1.30	\$ 1.50	
Amount Bid Price	\$ 9458.00	\$ 11822.50	\$ 14778.13	\$ 12295.40	\$ 14187.00	

JAMES J. DEAN
Superintendent of Highways
Roadmaster IV

Orangetown Representative:
R.C. Soil and Water Conservation Dist.-Chairman
Stormwater Consortium of Rockland County
Rockland County Water Quality Committee



HIGHWAY DEPARTMENT
TOWN OF ORANGETOWN
119 Route 303 · Orangeburg, NY 10962
(845) 359-6500 · Fax (845) 359-6062
E-Mail – highwaydept@orangetown.com

Affiliations:
American Public Works Association NY Metro Chapter
NYS Association of Town Superintendents of Highways
Hwy. Superintendents' Association of Rockland County

MEMORANDUM

TO: Town Board

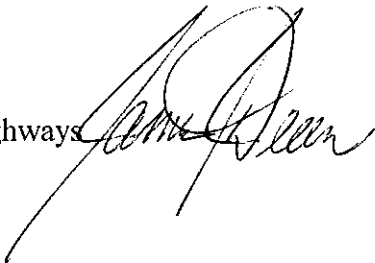
FROM: James J. Dean, Superintendent of Highways 

DATE: April 19, 2021

RE: **Award Bid for Industrial Service Uniform Bid**

Please be advised I respectfully recommend the above referenced Industrial Service Uniforms Contract be awarded to American Wear Uniforms, the only bidder.

For your information, the current contract cost per person is \$1.69 per employee, per week.

Please add the following item to the Town Board Workshop Agenda of April 27, 2021:

WHEREAS, the Superintendent of Highways duly advertised for sealed bids for Industrial Service Uniforms, which were received and publicly opened on April 15, 2021. Now, Therefore, Be It

RESOLVED, upon the recommendation from the Superintendent of Highways, that the Town Board hereby awards this bid to American Wear Uniforms, East Orange, N.J., the only bidder, at a price of \$1.87 per employee, per week for a two (2) year contract period.

JJD/Kf
Attachment





THE NOBLE NINTH, INC.
149-3911th Ave
Whitestone, N.Y. 11357-1720
(516) 236-3847



04/07/2020

Mr. Aric T. Gorton
Superintendent, Town of Orangetown
81 Hunt Rd
Orangeburg, NY 10962

Re: Orangetown Day Camp Scheduled July 7th – August 13th, 2021

Dear Mr. Gorton:

The day camp is expected and welcome to enjoy the park weekdays from July 7th – August 13th, 2021 between the hours of 7:30 am - 5:15 pm. We understand that the day campers will be supervised by adults. We have been informed in the past that the campers will not be on site for Independence Day and the day after. We ask you to provide the date(s) that the campers will not be on sight if necessary.

In the past, Mr. Mark Albert has been our contact for this and we are also aware that there is some setup and lead time that the camp counselors need for preparation and breakdown of their gear. Please provide their specific dates and any other requirements via email to me. See the attached trustee list for our contact information.

The Noble Ninth Inc is in receipt of this year's Insurance certificate showing the NN9 as additional Insured.

I am enclosing the board's 2021 roster and contact list should you or your agents need to speak to one of us or if you need to provide our contact information to your constituents. The 2021 NN9 park chairmen has yet to be announced. Recently our dear board member Mr. John Hegener passed away suddenly and we are in a transition period while we look to fill the gap from this loss. I will be your first contact and our president Jan Weinrich is the secondary.

Please forward this letter to all you feel need or require it. If you need anything else, please do not hesitate to reach out to me directly. My direct dial is noted above. It is a privilege to again host this worthy endeavor.

Sincerely & Fraternaly,

Mark Rampanelli, Treasurer
The Noble Ninth Inc.

Trustees

Joseph Kemmet President

Rick Schneider VP

*Mark Rampanelli
Treasurer*

Kelvis Parra Secretary

Paul Ottati Trustee

Michael Kenny Trustee

Trustee



PLAN

SCALE: 1"=50'



W17-1



W16-7P



W16-9P

M.U.T.C.D. STANDARD TRAFFIC SIGNS

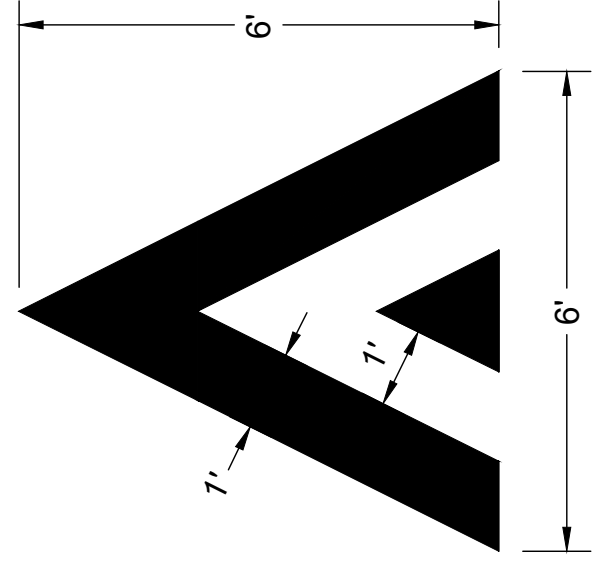

SPEED TABLE MARKING

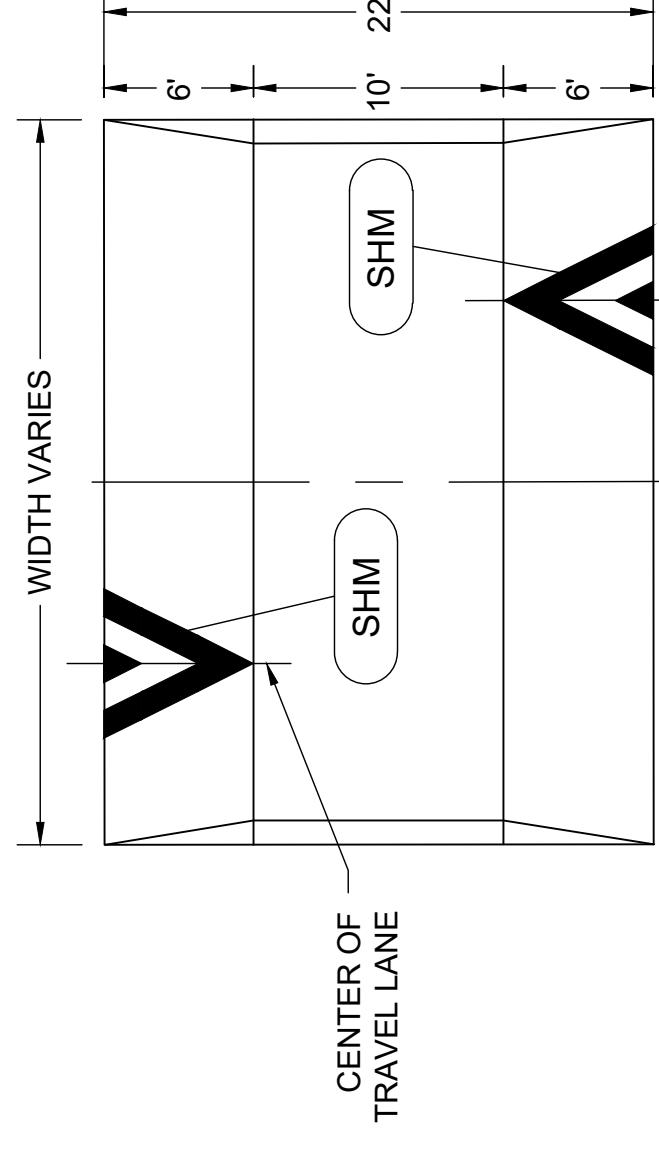

SPEED TABLE PLAN VIEW

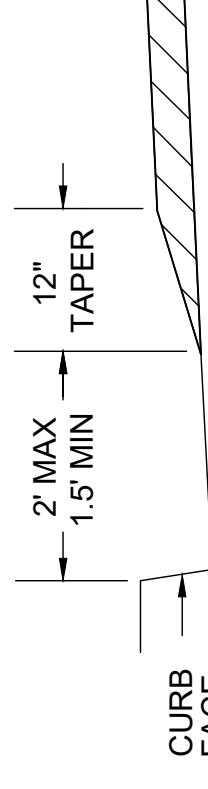

SECTION B-B CURB DETAIL

TYPICAL TRANSITION TO GUTTER DETAIL

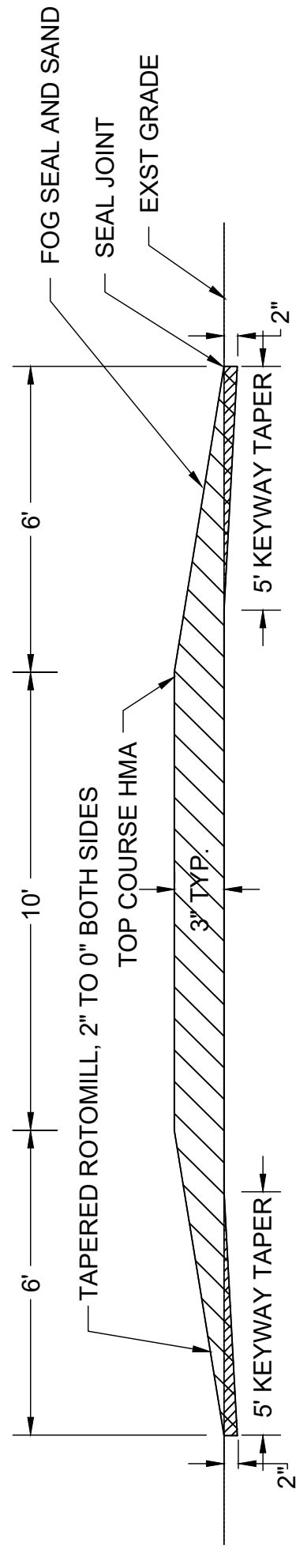
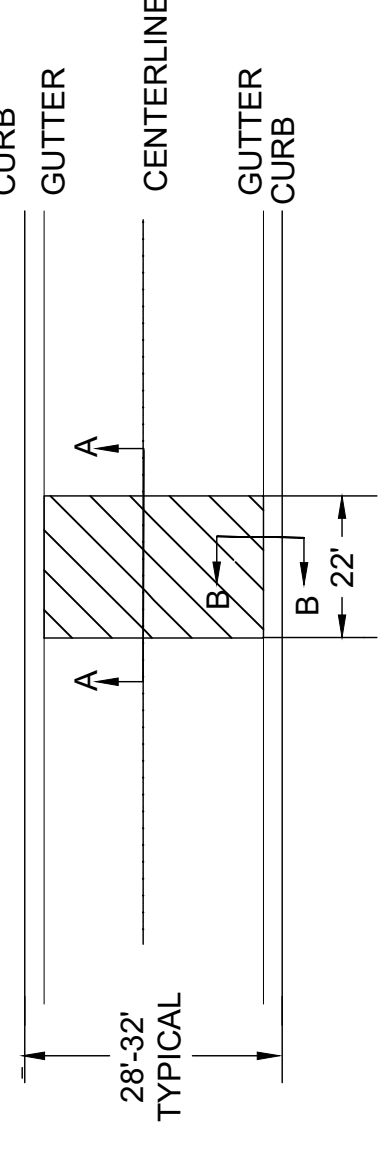

SPEED TABLE - SECTION A-A

LIVINGSTON ST. TRAFFIC CALMING PROJECT

TAPPAN, N.Y.

Town of Orangetown

Town Hall 26 West Orangeburg Road • Orangeburg, NY 10962
Telephone: (845) 359-5100 ext. 2293
Fax: (845) 359-2623
e-mail: myannazzone@orangetown.com
website: www.orangetown.com



Michael Yannazzone
Chairperson
Orangetown Traffic Advisory Board

February 22, 2021

Dear Resident:

The Traffic Advisory Board (TAB) convened for a meeting on Monday, February 8, 2021, to discuss the recommendation of the Traffic Technical Advisory Committee (TTAC) for Physical Traffic Calming Measures to be installed on Livingston Street in Tappan. **(Please see enclosed map).**

The TTAC made the following recommendation:

- Install three (3) speed tables on Livingston Street

The TAB unanimously approved the Physical Traffic Calming Measures for Livingston Street. Prior to forwarding to the Town Board for approval, a petition signed by at least 75% of the total occupied households on the specific street that is the subject of the proposed traffic calming measures is needed for implementation. This petition will also be sent to Emergency Services for their review.

Please complete the form below and return to the above noted address or you may e-mail your approval or disapproval to akardon@orangetown.com. If you have any questions or need further information, please feel free to contact Allison Kardon, Clerk to the Orangetown Traffic Advisory Board at 845-359-5100 x2293, or e-mail her at the aforementioned e-mail address.

Very truly yours,

Michael Yannazzone
Chairperson
Orangetown Traffic Advisory Board

Petition for Three Speed Tables on Livingston Street

Print Name: _____ Date: _____

Signature: _____

Full Address (Street, City, State) _____

Approve

Disapprove

Livingston Petition Results for 3 Speed Tables 2021	
# of Occupied Households	20
Approve	15
Disapprove	0
No Response	5
75% Approval Reached (15 needed)	yes
EMS and Fire	approve

**TOWN OF ORANGETOWN
FINANCE OFFICE MEMORANDUM**

TO: THE TOWN BOARD
FROM: JEFF BENCIK, *DIRECTOR OF FINANCE*
SUBJECT: AUDIT MEMO
DATE: 4/22/2021
CC: DEPARTMENT HEADS



The audit for the Town Board Meeting of 4/27/2021 consists of 3 warrants for a total of \$683,101.43.

The first warrant had 2 vouchers for \$43,581.32 and had the following items of interest.

1. NY Power Authority (p1) - \$43,581 for street light project.

The second warrant had 2 vouchers for \$5,698 and was for golf cart leases.

The third warrant had 133 vouchers for \$633,821 and had the following items of interest.

2. Chazen Engineering (p11) - \$5,550 for land surveying.
3. CSEA Employee Benefit Fund (p14) - \$31,058 for CSEA Dental benefits.
4. Foley Signs (p16) - \$5,485 for replacement sign.
5. Goosetown Enterprises (p18) - \$5,625 for police leases.
6. Hayden Bldg. Maint. Corp. (p21) - \$8,927 for roof repairs Blue Hill.
7. Helmke (p22) - \$5,000 return of bid bond.
8. Journal News Media Group (p27) - \$6,714 for advertising.
9. Ken's Tree Care (p27) - \$5,364 for tree removal.
10. Northern Supply Inc. (p31) - \$7,290 for Highway equipment.
11. Siemen's (p39) - \$21,145 for Energy performance contract.
12. State Comptroller (p41) - \$42,234 for Justice fines.
13. Susan R. Bauer (p41) - \$11,978 for Rigging/Trickle Tank.
14. Tomco Construction (p44) - \$226,544 Homes for Heroes project (reimbursable).
15. Transportation & Repairs (p46) - \$7,500 for Sewer trucks.

16. US Pitchcare (p47) - \$131,157 for Blue Hill bunker project.

17. Zarin & Steinmetz (p48) - \$10,620 for outside counsel.

Please feel free to contact me with any questions or comments.

Jeffrey W. Bencik, CFA

845-359-5100 x2204

WARRANT

Warrant Reference	Warrant #	Amount
Approved for payment in the amount of		
	041321A	\$ 43,581.32
	042321	\$ 5,698.70
	042721	\$ 633,821.41
	Total	\$ 683,101.43

The above listed claims are approved and ordered paid from the appropriations indicated.

APPROVAL FOR PAYMENT

AUDITING BOARD

Councilman Gerald Bottari

Councilman Paul Valentine

Councilman Thomas Diviny

Councilman Denis Troy

Supervisor Teresa M. Kenny